



Diamond Tub & Showers Spec Sheet

Model: TOA 603723 L/R (Left Shown)

Description: Tub Only with Apron

Specifications

Model #	Material	Wall Finish	Pieces	Drain	Apron Height	Net Weight Lbs.
TOA 603723 L/R	Fiberglass/ Gelcoat	Smooth	1	Left/Right	22"	

Sump Data

Top of Drain to Bottom of Overflow	Capacity to Overflow Gallons	Top Dimensions		Bottom Dimensions	
		Length	Width	Length	Width
16 1/2"	78.0	55 1/4"	29	43"	24 3/4"

Framing Dimensions

A	B	C	D
60"	8 3/4"	18"	37 1/8"

Enclosure Opening

Length	Width
NA	NA

Framing Specifications

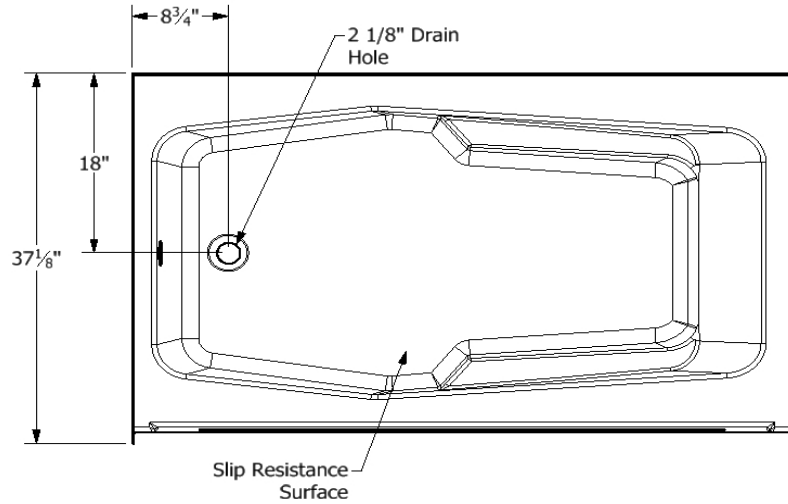
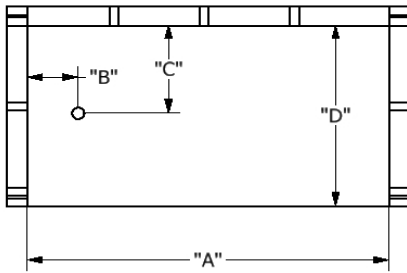

2 1/2" Overflow Hole

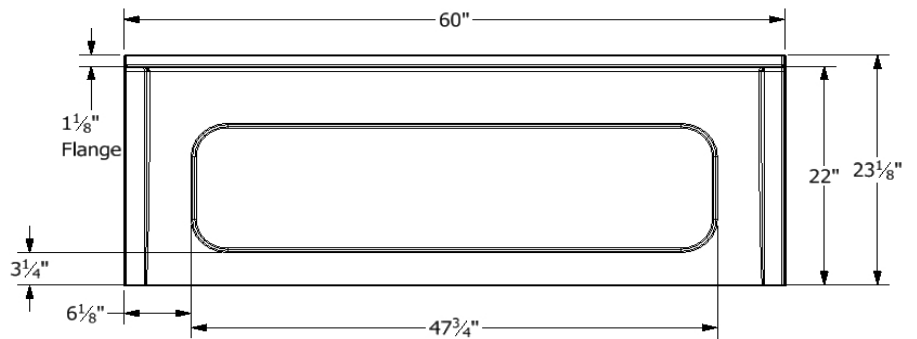
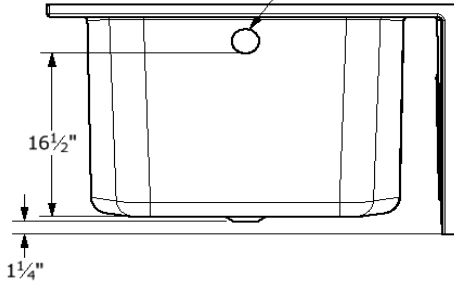

This product is tested by ICC-ES and is certified to conform to the requirements of CSA B45.5/IAMPO Z124

Manufactured by Front Line Mfg., Inc. Warsaw, IN



5/31/19