



# Diamond Tub & Showers Spec Sheet

Model: TR4 603175 R/L (TR4 603175 Left Shown)

Description: Tub/Shower Remodeler 4 Piece - Front Install Pin System

## Specifications

Model #	Material	Wall Finish	Pieces	Drain	Apron Height	Net Weight Lbs.
TR4 603175 R/L	Fiberglass/Gelcoat	Smooth	4	LH/RH	16"	

## Sump Data

Top of Drain to Bottom of Overflow	Capacity to Overflow Gallons	Top Dimensions		Bottom Dimensions	
		Length	Width	Length	Width
11"	50.0	55 3/4"	23 1/4"	47"	20 1/2"

## Framing Dimensions

A	B	C	D
60"	14 5/16"	7 3/4"	31 1/8"

## Enclosure Opening

Width	Height
56"	57 1/2"

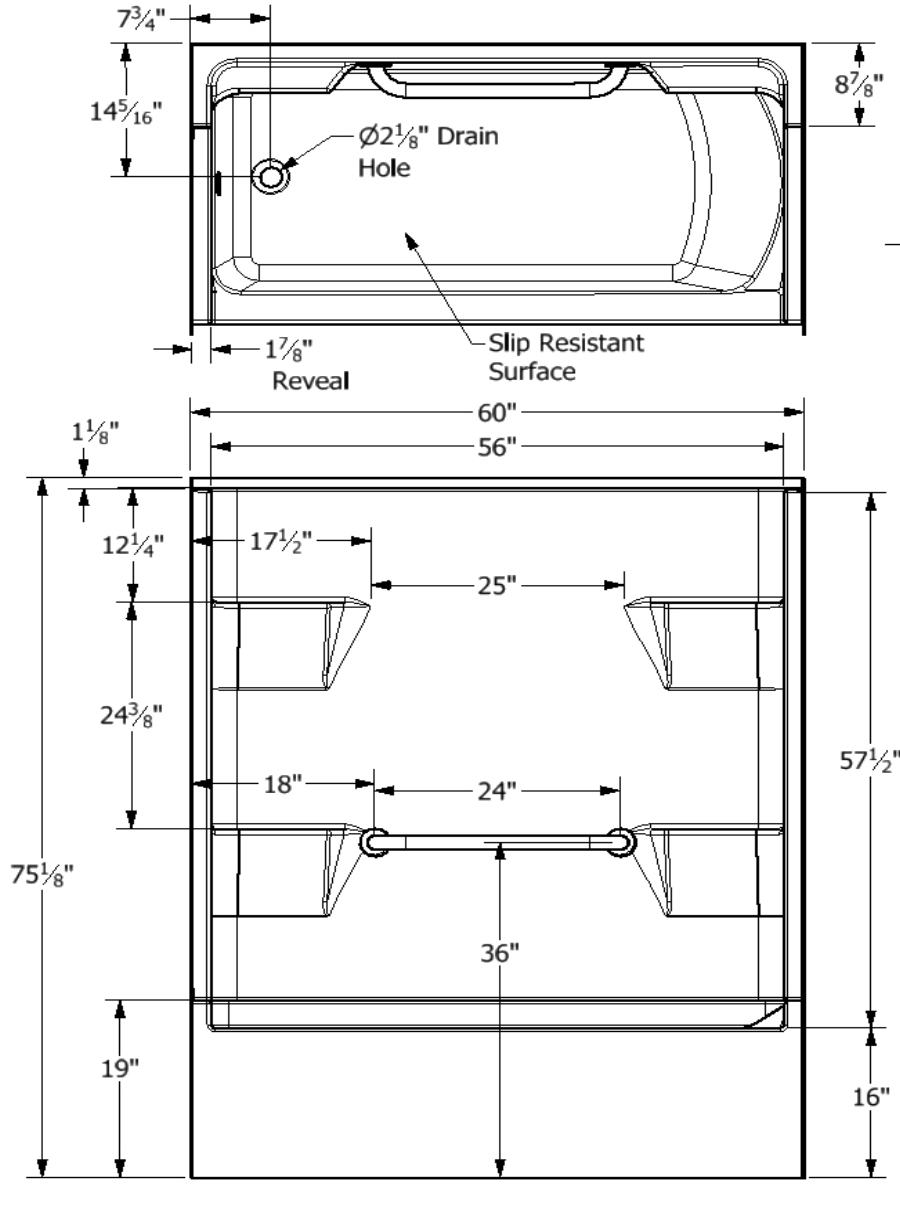

## Framing Specifications

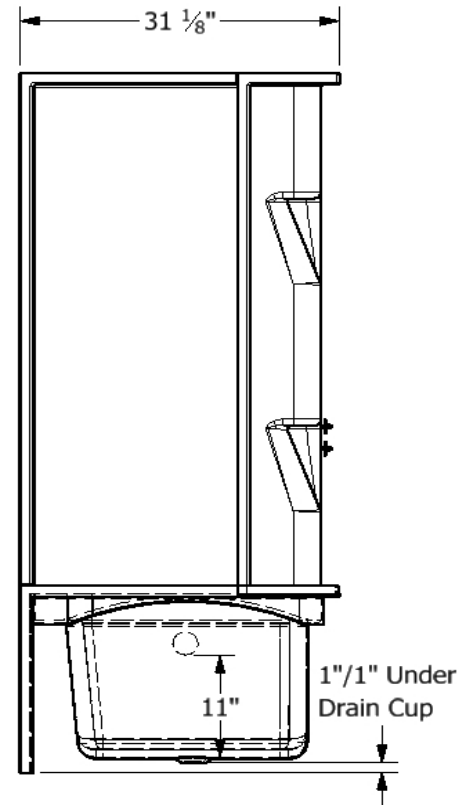
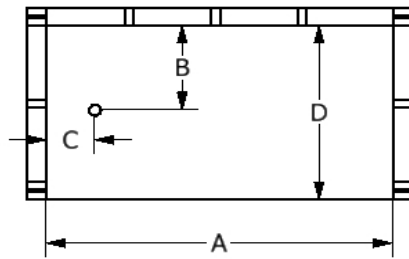

This product is tested by ICC-ES and is certified to conform to the requirements of CSA B45.5/IAMPO Z124 standard.

Manufactured by Front Line Mfg., Inc. Warsaw, IN



7/23/19